



104-AIO16A



KEY FEATURES:

- 500kHz sampling rate supported by wide data bus
- 16 single-ended or 8 differential inputs
- 11 software/hardware selectable ranges
- Unique channel by channel programmable gain of 1, 2, 5, and 10
- 1024 sample data FIFO for A/D
- Auto calibration
- Two 12-bit D/A outputs and 16 digital I/O

FACTORY OPTIONS:

- FIFO up to 64K samples
- Programmable amplifier with gains of 1, 10, 100, and 1000
- +5VDC only operation
- 0 to 70°C and -40 to +85°C versions available

The 104-AIO16A is a high-speed, 16-bit resolution board which provides speeds up to 500kHz for 16 single-ended or eight true differential analog input channels. This multifunction board features an excellent price/performance value for precision PC/104-based data acquisition, control, or signal analysis of standalone environmental test stations, compact production test equipment, portable testers, avionics and other applications.

The 104-AIO16A features 11 standard analog input ranges and a filtered, extremely quiet front end. The module also offers on-board hardware oversampling for additional noise reduction. In addition to direct data transfers, the board's ability to trigger the A/D in real time assures synchronized sampling that is unaffected by other computer operations—an essential requirement for signal, vibration and transient analysis where high data rates must be sustained for short periods of time. The 500kHz sampling rate is supported by a 1024-sample FIFO (optional, 2, 4, 32, and 64K samples) for reducing processor overhead. Sixteen parallel bits of digital I/O and two 12-bit D/A outputs allow for a complete,

high-performance data acquisition solution.

SOFTWARE

The 104-AIO16A is supported for use in most operating systems and includes a free DOS, Linux and Windows 95/98/Me/NT/2000/XP/2003 compatible software package. This contains sample programs and source code in "C" and Pascal for DOS, and Visual Basic, Delphi, C++ Builder, and Visual C++ for Windows. Also included is a graphical setup program in Windows. Linux support includes installation files and basic samples for programming from any user level via an open source kernel driver.

Data subject to change without notice.



104-AIO16A

Block Diagram & Pin Configuration

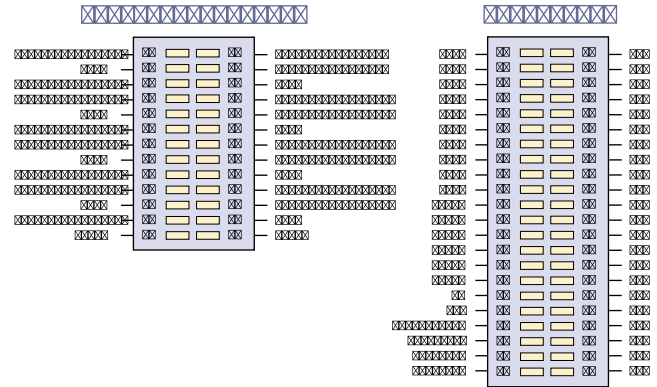
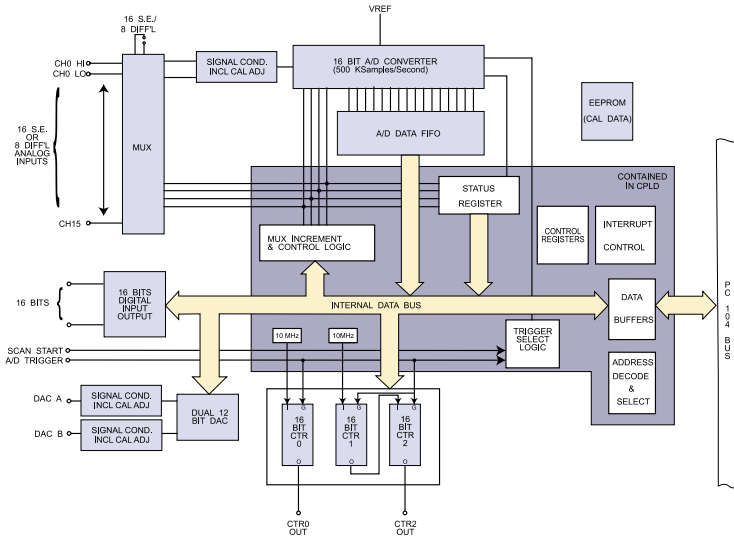

Specifications

A/D

Inputs	16 single-ended or 8 differential
Resolution	16-bit resolution
Bipolar ranges	±0.5V, ±1V, ±2V, ±2.5V, ±5V, ±10V
Unipolar ranges	0-1V, 0-2V, 0-4V, 0-5V, 0-10V
Sampling rate	500kHz
Type	Successive approximation
Oversvoltage protection	-37V to +52V
Nonlinearity	±4 LSB, monotonic
A/D FIFO	1024 16-bit wide samples (optional 2, 4, 32, and 64K)
Calibration	Offset and gain values stored in EEPROM
Trigger Source	Software selectable: external trigger, programmable timer, program command, A/D start, single scan start

D/A

Outputs	2
Resolution	12-bit resolution
Ranges	0-5V, 0-10V
Relative accuracy	±2 LSB
Diff. Nonlinearity	±0.2 LSB
Settling time/Update rate	8µs/100kHz
Output current	5mA
Calibration	Gain values stored in EEPROM

Digital I/O

Number of I/O	16, programmable as inputs or outputs in groups of 8
Input voltage	Logic low: 0.0V min, 0.8V max; Logic high: 2.0V min, 5.0V max
Input current	±1µA max
Outputs	Logic low: 0.0V min, 0.55V max; Logic high: 2.4V min, 5.0V max
Output current	Logic low: 24mA max sink; Logic high: 24mA max source

Counter/Timers

Type	82C54
A/D Pacer clock	16 or 32-bit
Clock Frequency	10MHz

General

Power required (using optional DC/DC converter)	+5V at 190mA typ
Power required (using ±12V and +5V)	+12VDC - 25mA typical, -12VDC - 25mA typical, +5VDC - 65mA typical
Operating Temperature	0 to +70°C, optional -40 to +85°C
Storage Temperature	-50 to +120°C
Humidity	5% to 90% RH, non-condensing

Ordering Guide

104-AIO16A 16-bit, High-Speed, 16-channel A/D with 12-bit D/A

Data subject to change without notice.