

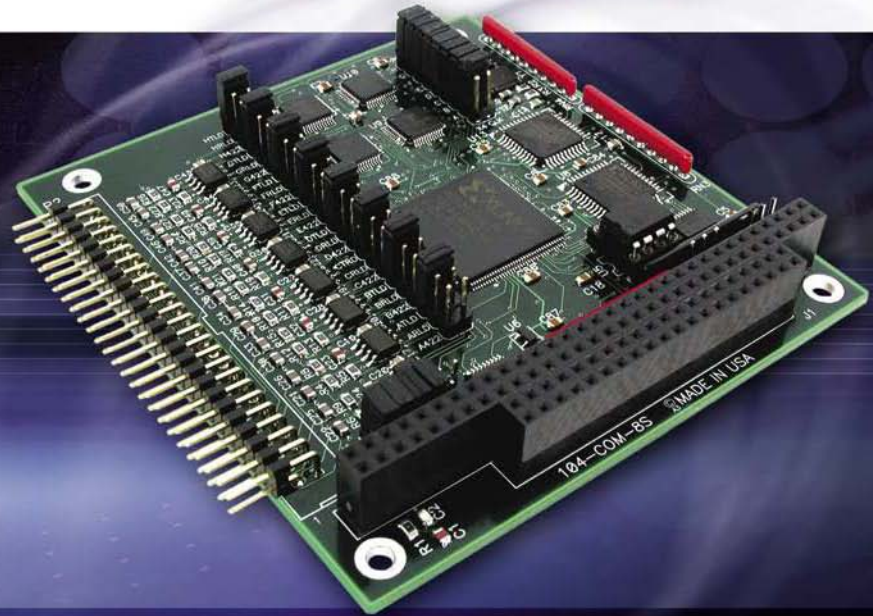

104-COM-8S/104-COM-4S/104-COM-2S



KEY FEATURES:

- 8, 4 or 2 independent asynchronous serial COM ports
- Field selectable RS-422 and RS-485, independent for each port
- Auto-RTS feature makes half-duplex RS-485 communications effortless
- Speeds up to 921.6K
- Fixed bias and jumper selectable termination provided on each transmit and receive channel simplifies cabling
- Low power required: +5VDC at 80mA typical

Programmable individual non-volatile base addresses and IRQs simplifies installation

Operates as a standard COM port in all operating systems

FACTORY OPTIONS:

- 16850 UARTS with 128-byte FIFO
- 0 to 70°C and -40 to +85°C versions available

The 104-COM-8S Series are eight, four, or two-port, asynchronous, serial communication boards that support both RS-485 and RS-422 communications. Ideal for POS, gaming systems, machine monitoring, military, and high-density networking applications, these boards may be installed in any system with PC/104 support. Ports are accessed via a 50-pin IDC type right angle connector.

This board may be operated in two modes. In the Default Mode, the base address for the board is selected by jumpers and all of the channel addresses are sequential. Alternately, the addresses and interrupts of the individual channels may be stored in non-volatile memory on the board and loaded into programmed logic when the board is initially powered. Individual

interrupts for each channel are programmed into the non-volatile memory in both modes.

The boards include a convenient Auto-RTS feature, which makes half-duplex RS-485 communications effortless. The 104-COM-8S Series offer optional type 16850 UARTS with 128-byte transmit/receive FIFO buffers to protect against lost data in multi-tasking systems while maintaining 100% compatibility with all operating system COM port drivers. A jumper selection on the board permits baud rate capability up to 921.6K. ADL offers the 104-COM-8S Series in both standard and extended temperature versions ideal for outdoor applications or harsh industrial surroundings.

SOFTWARE

The 104-COM-8S Series is supported for use in all operating systems and include a free DOS, Linux and Windows 95/98/Me/NT/2000/XP/2003 compatible software package. This includes sample programs and source code in "C" and Pascal for DOS, and Visual Basic, Delphi, C++ Builder, and Visual C++ for Windows. Also included is a graphical setup program in Windows. Embedded OS support includes Windows XPe and CE. An easy-to-use Windows terminal program simplifies verification of proper operation.

Data subject to change without notice.



104-COM-8S/104-COM-4S/104-COM-2S

Block Diagram & Pin Configuration

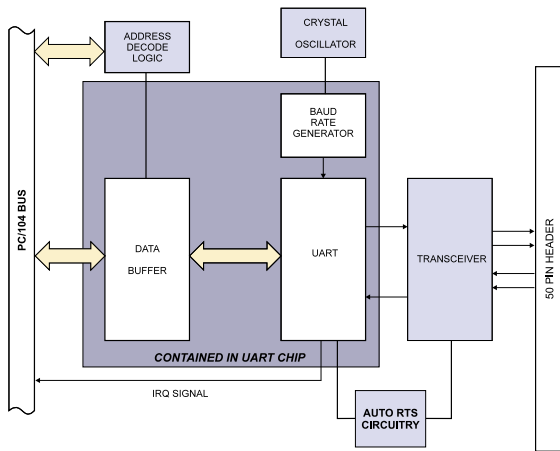

RS-422 Functions

GND	01	02	PORT0 Tx+
PORT0 Tx-	03	04	GND
PORT0 Rx+	05	06	PORT0 Rx-
GND	07	08	PORT1 Tx+
PORT1 Tx-	09	10	GND
PORT1 Rx+	11	12	PORT1 Rx-
GND	13	14	PORT2 Tx+
PORT2 Tx-	15	16	GND
PORT2 Rx+	17	18	PORT2 Rx-
GND	19	20	PORT3 Tx+
PORT3 Tx-	21	22	GND
PORT3 Rx+	23	24	PORT3 Rx-
GND	25	26	PORT4 Tx+
PORT4 Tx-	27	28	GND
PORT4 Rx+	29	30	PORT4 Rx-
GND	31	32	PORT5 Tx+
PORT5 Tx-	33	34	GND
PORT5 Rx+	35	36	PORT5 Rx-
GND	37	38	PORT6 Tx+
PORT6 Tx-	39	40	GND
PORT6 Rx+	41	42	PORT6 Rx-
GND	43	44	PORT7 Tx+
PORT7 Tx-	45	46	GND
PORT7 Rx+	47	48	PORT7 Rx-
GND	49	50	GND

RS-485 Functions

GND	01	02	PORT0 Tx/Rx+
PORT0 Tx/Rx-	03	04	GND
NC	05	06	NC
GND	07	08	PORT1 Tx/Rx+
PORT1 Tx/Rx-	09	10	GND
NC	11	12	NC
GND	13	14	PORT2 Tx/Rx+
PORT2 Tx/Rx-	15	16	GND
NC	17	18	NC
GND	19	20	PORT3 Tx/Rx+
PORT3 Tx/Rx-	21	22	GND
NC	23	24	NC
GND	25	26	PORT4 Tx/Rx+
PORT4 Tx/Rx-	27	28	GND
NC	29	30	NC
GND	31	32	PORT5 Tx/Rx+
PORT5 Tx/Rx-	33	34	GND
NC	35	36	NC
GND	37	38	PORT6 Tx/Rx+
PORT6 Tx/Rx-	39	40	GND
NC	41	42	NC
GND	43	44	PORT7 Tx/Rx+
PORT7 Tx/Rx-	45	46	GND
NC	47	48	NC
GND	49	50	GND

Specifications

Serial Ports

Number of serial ports	8, 4, or 2
Protocol	RS-422 and RS-485, independent for each port
Maximum baud rate	921.6K
Character length	5, 6, 7, or 8 data bits
Parity	Even, odd, or none
Receiver input sensitivity	±200mV differential input. Lines include factory bias and jumper selectable termination.
Common mode voltage range	+12V to -7V
Transmitter output drive capability	60mA with thermal shutdown. Lines include factory bias and jumper selectable termination.
Base address options	Programmable
Interrupts	Individual IRQs for each channel are stored onboard in non-volatile memory

General

I/O connections	Via a 50 pin IDC type right angle connector. There are four pins per port plus common grounds.
Short circuit protection	All outputs protected against continuous short circuit
Power required	+5VDC at 80mA typical, all outputs open
Operating temperature	-40 to +85°C optional, all versions
Operating humidity	5% to 95% RH, non-condensing
PC/104 bus	8-bit and 16-bit bus headers are used

Ordering Guide

104-COM-8S	8-port RS-422/485
104-COM-4S	4-port RS-422/485
104-COM-2S	2-port RS-422/485

Data subject to change without notice.