

ADLPS104CF

Manual

Rev. 1.3

Table of Contents

0	History.....	5
1	Introduction.....	6
1.1	General Precautions.....	6
1.2	Technical Support.....	6
1.3	Warranty.....	6
1.4	Return Authorization.....	6
2	Overview.....	7
2.1	Standard Features.....	7
2.2	Optional Features.....	7
2.3	Summary of Features.....	8
2.4	Ratings.....	8
2.5	Specifications and Documents.....	8
2.6	Trade Marks.....	9
3	Detailed Description.....	10
3.1	Power Supply.....	10
3.2	IDE Interface.....	10
3.3	Battery.....	10
3.4	PC/104 and PC/104+ Interface.....	10
4	Connectors.....	11
4.1	Power Input (P204).....	11
4.2	Main Power Output (P206).....	12
4.3	Auxiliary I/O (P207).....	13
4.4	CPU Supply Output (P203).....	14
4.5	PC/104 Bus (PC104 rows A-B = P200, PC104 rows C/D = P202).....	15
4.6	PC/104-Plus Bus (P201).....	16
4.7	IDE / CF Functions (P100, P101, P102 Top, P103 Bottom).....	17
4.8	PCB.....	19
4.9	Heatsink.....	20
5	Jumpers / LED Criterion.....	21
5.1	Compact Flash Master Select (J100).....	21
5.2	Compact Flash I/O Voltage Select.....	21
5.3	Ultra-DMA (UDMA) Mode Enable.....	21
5.4	RTC Battery enable.....	21
5.5	LED Indicators.....	22

History

6	Technical Data	23
6.1	Electrical Data	23
6.2	Environmental Conditions	23
7	Thermal Specifications.....	24

0 History

Version	Description	Changes
1.0	Board Rev D0	First Release
1.1	Board Rev D1	Ripple Reduction, Battery jumper,
1.2	Board Rev D1	Design update of Chapter one in Manual
1.3	Board Rev D1	- Indicate Pin 1 on Connectors (page 10&11) - warning message about failing power supply added on page 21

1 Introduction

1.1 General Precautions

This product is intended to be used by persons, experienced in the use of electronic equipment in an ESD-safe environment. Appropriate precautions should be taken to ensure safe working conditions while handling or operating this module.

It is the responsibility of the user to ensure proper handling of this product.



Attention

Failure to follow the instructions and precautions as directed by this manual may void your warranty.

1.2 Technical Support

Technical support for this product can be obtained by contacting ADL in the following methods:

- By contacting our support staff at 858 490-0597 ext.13
- By contacting our staff via e-mail at support@adl-usa.com
- Via our website at www.adl-usa.com/support/index.html

1.3 Warranty

This product is warranted to be free of defects in workmanship and material. ADL's sole obligation under this warranty is to provide replacement parts or repair service at no charge, excepting shipping cost. Such defects which appear within 12 months of original shipment from ADL will be covered, provided a written claim for service under warranty is received by ADL no less than 30 days prior to the end of the warranty period of within 30 days of discovery of the defect – whichever comes first. Warranty coverage is contingent upon proper handling and operation of the product. Improper use such as unauthorized modifications or repair, operation outside of specified ratings, or physical damage may void any service claims under warranty.

1.4 Return Authorization

All equipment returned to ADL for evaluation, repair, credit return, modification, or any other reason must be accompanied by an RMA number. In order to obtain an RMA authorization we will need a completed RMA form submitted by email to RMA@adl-usa.com or faxed to 858-490-0599. This form can be obtained at our website: www.adl-usa.com . Following a review of the information provided we will issue a return authorization number.

2 Overview

2.1 Standard Features

The ADLPS104CF is a multi-featured PC104 peripheral board intended for use with the ADL8xx series CPU board. Its primary function is a high-current 5 volt power supply, with visual indicators for output power, IDE activity, and power supply output quality. Additional options include dual type-II compact flash sockets, pass-through IDE interface, and battery backup for the RTC. Pass-through PCI connectors are optional for PC104-Plus compliance.

This product is intended to stack directly below the CPU board. In order to do so, the CPU board must be modified to mate with the ADLPS104CF.

2.2 Optional Features

- Second CF Type II Socket on Bottom of the board
- Heatsink for additional thermal dissipation

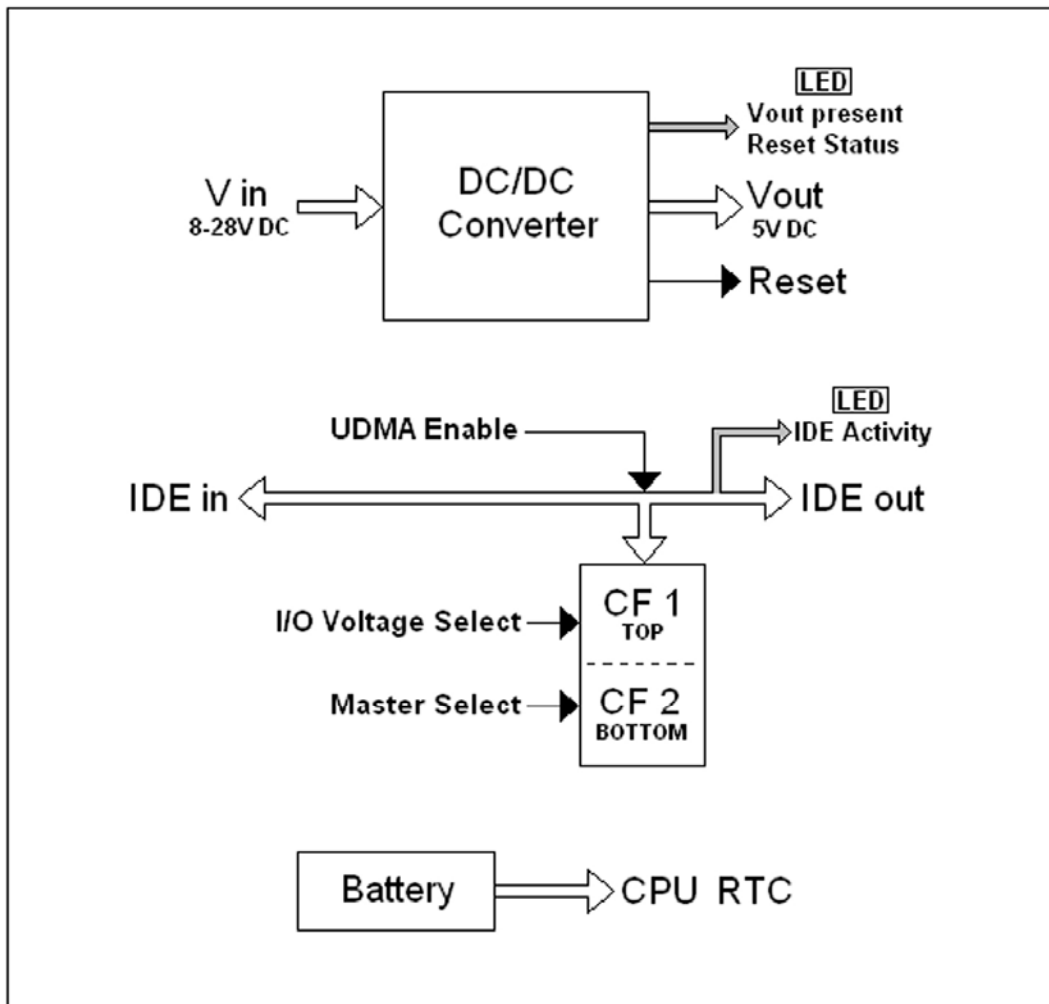

ADLPS104CF FUNCTIONAL DIAGRAM

2.3 Summary of Features

Regulated 5 volt DC output power supply with wide-range DC input
Standard single Type II and optional dual Type II Compact Flash via IDE interface
Additional pass-through IDE interface
Lithium (non-rechargeable) RTC battery for CPU board
LED indicators for power supply and IDE status

2.4 Ratings

Voltage Input Range:	8 – 28V DC
Efficiency:	>90% (typ.)
Output Voltage:	5V DC +/-5%
Output Current:	Maximum 10A without additional thermal dissipation (50W) Maximum 20A with optional thermal dissipation (100W)
Operating Temperature Range:	-40C to +70C ambient
Storage Temperature Range:	-40C to 125C

2.5 Specifications and Documents

The following technical documents, specifications, and web-pages were referenced when making this document. Please refer to these additional sources if you need additional technical information not found in this manual.

- ISA specification
IEEE996P
www.ieee.org

- PC/104 specification
Version 2.5
www.pc104.org

- PC/104-Plus specification
Version 2.0
www.pc104.org

- PCI specification
Version 2.3
www.pcisig.com

- ACPI specification
Version 2.0
www.acpi.info

- ATA/ATAPI specification
Version 7 Rev. 1
www.t13.org

2.6 Trade Marks

All trade marks are accepted.

3 Detailed Description

3.1 Power Supply

The ADLPS104CF's primary function is a high-current power supply intended to power a high-performance PC104+ CPU module. Power supply is output to the CPU board via the PC104 and PC104+ bus or an alternate connector P203.

The ADLPS104CF's design is intended to be simple yet effective and will operate automatically when given sufficient power input. No additional inputs are required to control the power supply function.

Two indicators display power supply status: D103 shows that output Vcc present and D100 shows power supply reset state. Power supply „Power Good“ (active low) status is also available on P206/Pin5 and P207/Pin1.

3.2 IDE Interface

Two compact flash sockets can be installed on the board. Master and slave, I/O voltage and UDMA mode selection are changeable via jumpers. An additional pass-through IDE connector is optional for accessibility.

An indicator D104 is provided for IDE activity status.

3.3 Battery

A 3.3V Lithium battery is onboard for RTC backup of the CPU board. Output is via P203 or the auxiliary output P207/Pin3.

J103 is used to disconnect the battery for diagnostic and transportation purposes.

3.4 PC/104 and PC/104+ Interface

The PC104 (ISA) bus interface is provided as a pass-through only, with exception of power supply output, which has the following connections: 5 volt output is connected to pins B3,B29,D17, and Ground is connected to pins A32,B1,B31,B32,C1,D1,D19,D20.

The PC104+ interface is required if 3.3V compact flash operation is desired, as 3.3V is sourced from this bus.

4 Connectors

4.1 Power Input (P204)

This is the main power input to the power supply. The mating connector is a Buchanan p/n 796634-4

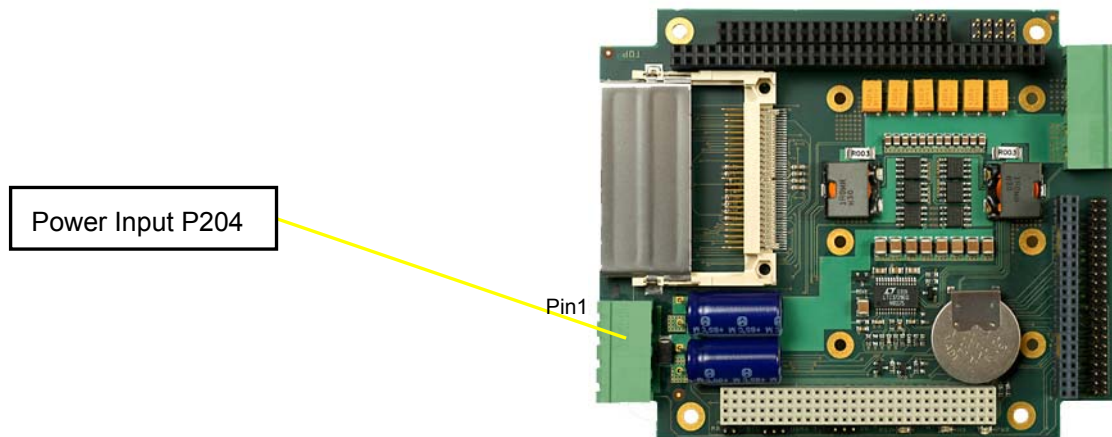

Description	Name	Pin	Name	Description
8 – 28VDC in	V _{in}	1	2	V _{in}
Ground	GND	3	4	GND

4.2 Main Power Output (P206)

This is the main power output from the power supply. The mating connector is a Buchanan p/n 796634-5.

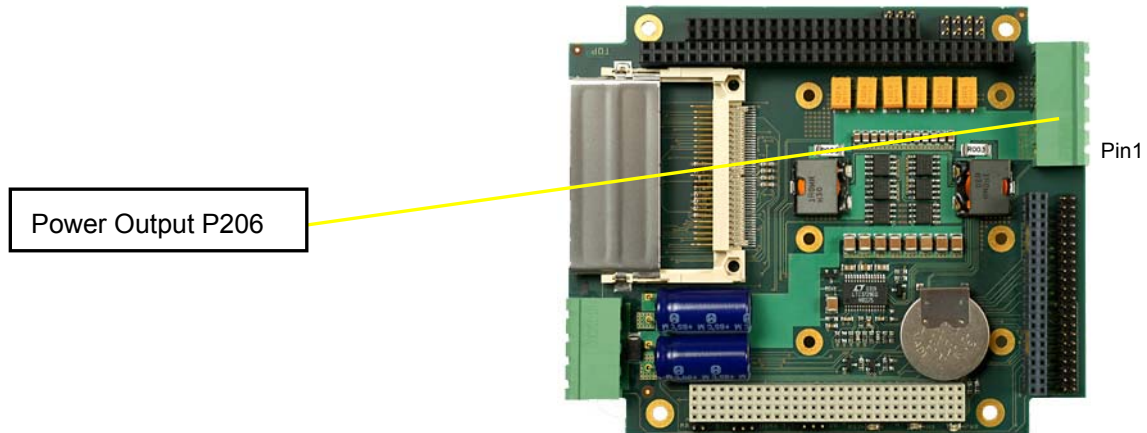

Description	Name	Pin	Name	Description
Regulated DC output	VCC	1 2	VCC	Regulated DC output
Ground	GND	3 4	GND	Ground
Power Good	RESET#	5		

4.3 Auxiliary I/O (P207)

Several auxiliary connections to board functions.

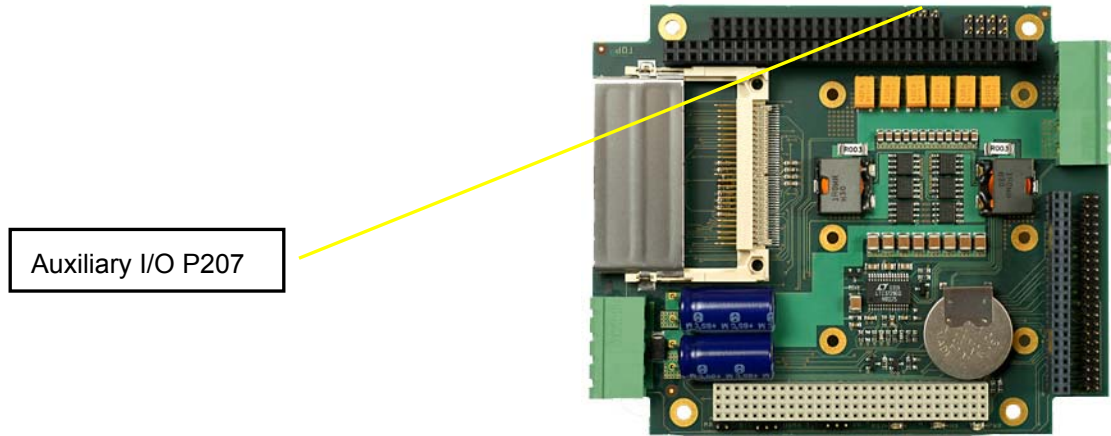

Auxiliary I/O P207

Description	Name	Pin		Name	Description
Power Good	RESET#	1	2	GND	Ground
Battery	V _{bat}	3	4		

4.4 CPU Supply Output (P203)

This is an alternate output of the power supply and RTC battery to the CPU board. Note pins 4, 5, and 6 are provided as pass-through connections only.

CPU Supply Output P203

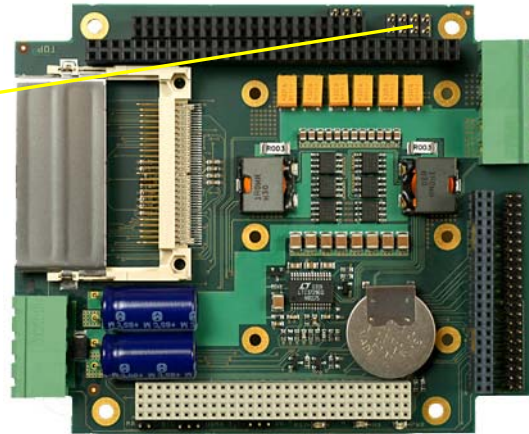

Description	Name	Pin		Name	Description
Ground	GND	1	2	VCC	Main 5V output
Battery	V _{bat}	3	4	(12V)	NC
NC	(-5V)	5	6	(-12V)	NC
Ground	GND	7	8	VCC	Main 5V output

4.5 PC/104 Bus (PC104 rows A-B = P200, PC104 rows C/D = P202)

Special Notes: Vcc output connected to pins B3, B29, and D17

GND output connected to pins A32, B1, B31, B32, C1, D1, D19, and D20

All other pins provided for pass-through compliance only

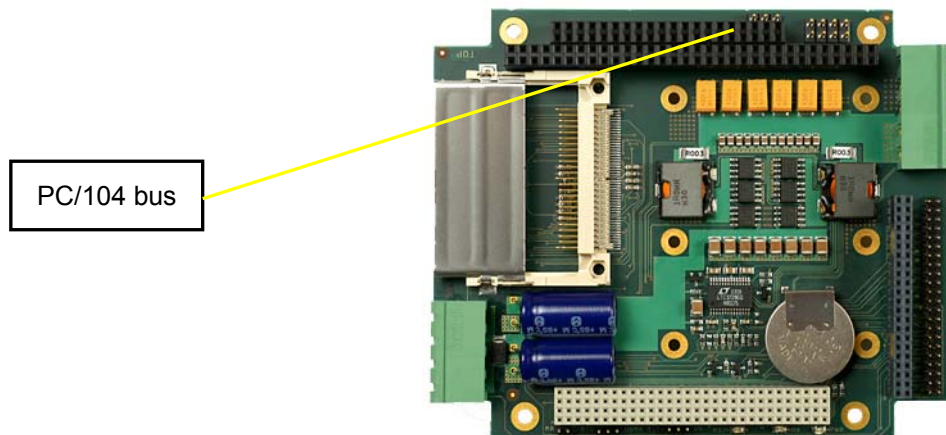

For details of the PC/104 bus refer to the PC/104 specification in Section 2.5 or the CPUs manual.

4.6 PC/104-Plus Bus (P201)

Special Notes: Vcc output connected to pins

A22, A26, B21, B27, C1, C24, C28, D2

GND output connected to pins

A1, A5, A10, A14, A20, A24, A28, B3, B9, B13, B18, B23, C4, C7, C12, C16, C22, C26,
D5, D11, D15, D20, D25, D27, D30

All other pins provided for pass-through compliance only

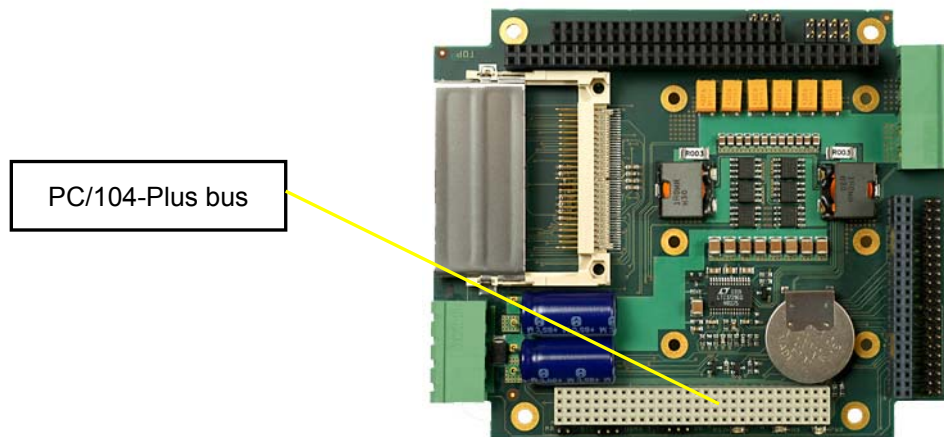

For details of the PC/104-Plus bus refer to the PC/104-Plus specification in Section 2.5 or the CPUs manual.

4.7 IDE / CF Functions (P100, P101, P102 Top, P103 Bottom)

The primary IDE interface is a standard IDC socket connector with a spacing of 2 mm. Most commercial IDE devices are supported, but an adapter to connect may be necessary.

P100: This is the interface to the CPU host for the onboard IDE function. It should be connected to the respective IDE interface on the CPU board

P101: This is a pass-through IDE connector provided for accessibility. Its operation is affected by the setting of J102. For details of this and other jumpers see Section 5.3.

P102: This is the standard Compact Flash socket (Top side)

P103: This is the optional Compact Flash sockets (Bottom side)

Note: Only two devices may be connected to the IDE interface at once, one master and one slave device.

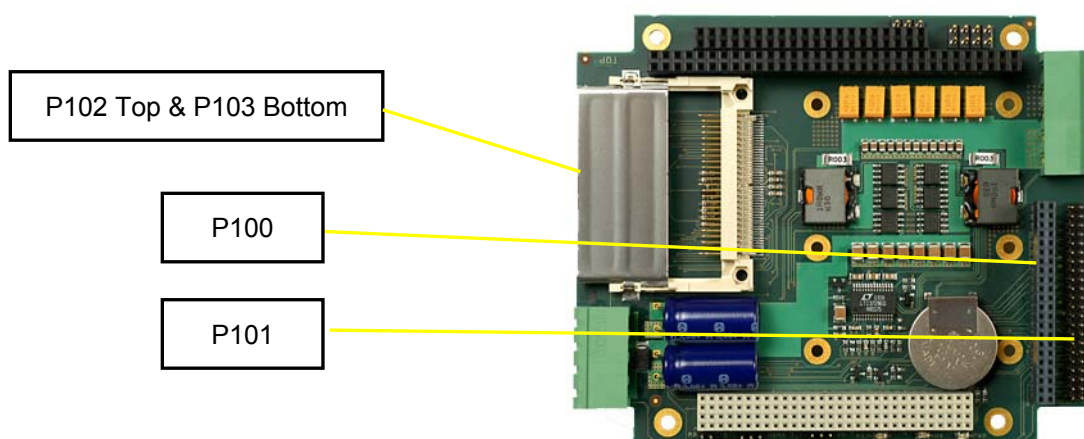

IDE: P100, P101					
Description	Name	Pin		Name	Description
reset	PRST#	1	2	GND	ground
data bit 7	PDD7	3	4	PDD8	data bit 8
data bit 6	PDD6	5	6	PDD9	data bit 9
data bit 5	PDD5	7	8	PDD10	data bit 10
data bit 4	PDD4	9	10	PDD11	data bit 11
data bit 3	PDD3	11	12	PDD12	data bit 12
data bit 2	PDD2	13	14	PDD13	data bit 13
data bit 1	PDD1	15	16	PDD14	data bit 14
data bit 0	PDD0	17	18	PDD15	data bit 15
ground	GND	19	20	reserved	
DMA request signal	PDDREQ	21	22	GND	ground
write signal	PDIOW#	23	24	GND	ground

Connectors

IDE: P100, P101					
Description	Name	Pin		Name	Description
read signal	PDIOR#	25	26	GND	ground
Ready signal	PDRDY	27	28	reserved	
DMA acknowledge signal	PDDACK#	29	30	GND	ground
interrupt signal	PDIRQ	31	32	reserved	
address bit 1	PDA1	33	34	PDIAG#	passed diagnostic
address bit 2	PDA0	35	36	PDA2	address bit 2
chip select signal 0	PDSC0#	37	38	PDCS1#	chip select signal 1
device active	DASP#	39	40	GND	ground
supply HDD 5V	VCC	41	42	VCC	Supply HDD 5V
ground	GND	43	44	Reserved	
CF: P102, P103					
Description	Name	Pin		Name	Description
Ground	Gnd	1	26	CD1#	Ground
data bit 3	D3	2	27	D11	data bit 11
data bit 4	D4	3	28	D12	data bit 12
data bit 5	D5	4	29	D13	data bit 13
data bit 6	D6	5	30	D14	data bit 14
data bit 7	D7	6	31	D15	data bit 15
	CE\IOCS0#	7	32	CE2#/CS1#	
address bit 10	A10	8	33	VS1#	
	OE/ATASEL#	9	34	IORD#	
address bit 9	A9	10	35	IOWR#	
address bit 8	A8	11	36	WE#	
address bit 7	A7	12	37	RDY\INTR	
	Vcc	13	38	Vcc	
address bit 6	A6	14	39	CSEL#	
address bit 5	A5	15	40	VS2#	
address bit 4	A4	16	41	RESET	Reset
address bit 3	A3	17	42	WAIT#/RDY	
address bit 2	A2	18	43	INPACK#	
address bit 1	A1	19	44	REG	
address bit 0	A0	20	45	BVD2/DASP#	
data bit 0	D0	21	46	BVD1/PDIAG#	
data bit 1	D1	22	47	D6	data bit 6
data bit 2	D2	23	48	D9	data bit 9
	WP\IOCS16#	24	49	D10	data bit 10
	CD2#	25	50	GND	Ground

4.8 PCB

This is a true dimensional drawing of the board incl. the mounting holes

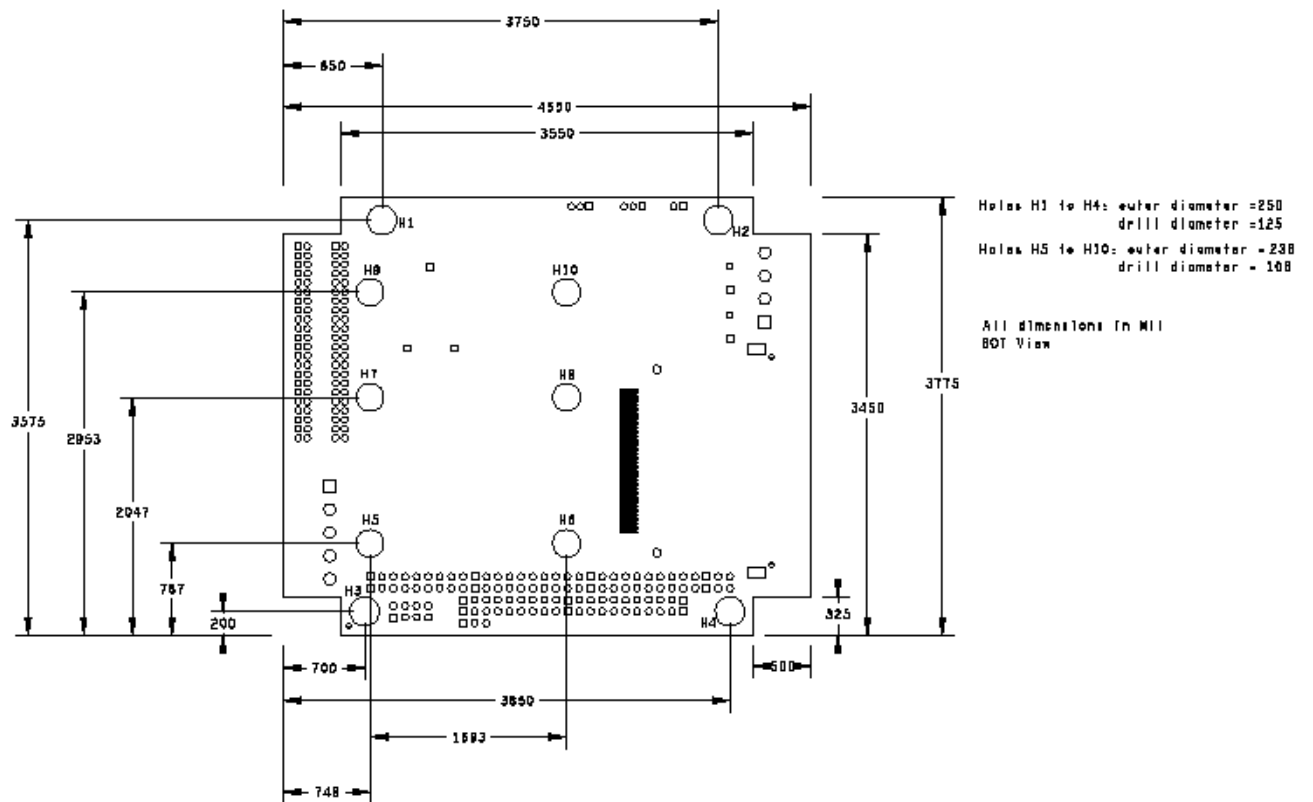

Attention

All dimensions are in mils.

4.9 Heatsink

For maximum thermal dissipation a heat sink must be mounted to the bottom side of the board.
(See section 2.3 for ratings).

This is a true dimensional drawing of a typical heatsink.

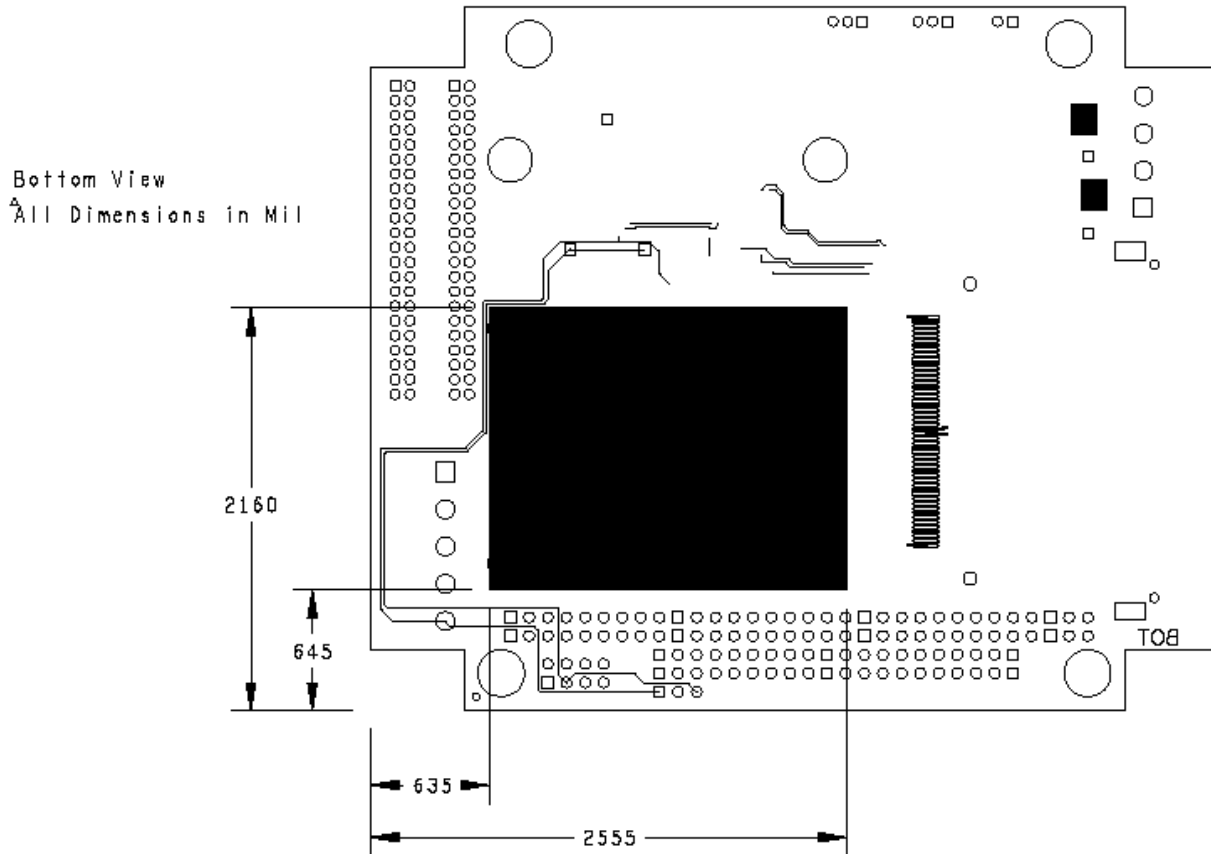

Attention

All dimensions are in mils.

5 Jumpers / LED Criterion



Attention

In the event that the power supply fails to start the system (Red LED remains illuminated), remove power supply from the system and apply power to only the power supply, one time only. If the Red LED illuminates briefly and extinguishes, contact ADL for an RMA. Do not repeatedly apply power to a failed supply.

5.1 Compact Flash Master Select (J100)

Open: (Default) Top side socket is master, and bottom side is slave

Closed: Bottom side is master, and top side is slave.

5.2 Compact Flash I/O Voltage Select

1 – 2: 3.3 volt I/O voltage (Note: PC/104+ option required to use this setting)

2 – 3: (Default) 5.0 volt I/O voltage

5.3 Ultra-DMA (UDMA) Mode Enable

1 – 2: UDMA mode enabled

2 – 3: (Default) UDMA mode disabled

NOTE: This jumper affects P101, P102, and P103

If J102 is in UDMA mode then all drives connected to the ADLPS104CF (P100, P102 and/or P103) will function as if an 80-conductor cable is in use. Improper cable construction may affect UDMA performance of devices connected to P101.

5.4 RTC Battery enable

Open: Disabled. The battery is disconnected from all circuits. Use this setting for storage or when no RTC backup is required

Closed: Enabled The battery is connected to P203, pin3 to supply voltage to the CPU's RTC circuit and to P207, pin3 for optional external reference.

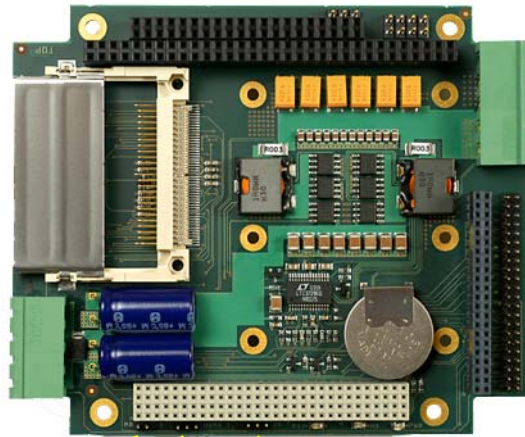

J100

J102

J101

5.5 LED Indicators

designation	name	color	indication when lit.
D100	RESET#	red	power supply reset asserted; VCC output <4.625V
D103	VCC	green	Output VCC present
D104	PDIAG	yellow	IDE activity



D103

D104

D100

6 Technical Data

6.1 Electrical Data

Power Supply: Board: TBD
 RTC: 3V nominal

Electric Power Consumption: Board: TBD

6.2 Environmental Conditions

Temperature Range: Operating: 0°C up to +60°C, extended on request
 Storage: 0°C up to +60°C
 Dispatch: -20°C up to +70°C, for packaged boards

Temperature Changes: Operating: 0.5°C per minute, 7.5°C per 30 minutes
 Storage: 0.5°C per minute
 Dispatch: 1.0°C per minute, for packaged boards

Relative Humidity: Operating: 5% up to 85%, (non condensing)
 Storage: 5% up to 95%, (non condensing)
 Dispatch: 5% up to 100% for packaged boards, (non condensing)

Shock: Operating: 150m/s, 6ms
 Storage: 400m/s, 6ms
 Dispatch: 400m/s, 6ms, for packaged boards

Vibrations: Operating: 10 up to 58Hz, 0,075mm amplitude
 58 up to 500Hz, 10m/s
 Storage: 5 up to 9Hz, 2.5mm amplitude
 9 up to 500Hz, 10m/s
 Dispatch: 5 up to 9Hz, 3.5mm amplitude
 9 up to 500Hz, 10m/s, for packaged boards

MTBF: 300,000h

7 Thermal Specifications



Attention

TBD