



USB-DA12-8A - USB 8 Channel Analog Output Module

FEATURES

- High-speed USB 2.0 device
- Up to 125K conversions per DAC per second
- Streaming waveform data at over 400,000 DAC outputs per second total
- 128K Sample buffer on-board, or Infinitely long streaming waveforms!
- Buffered waveforms at up to 1 million DAC conversions per second total
- ILDA compatible
- Small, portable 8-channel, 12-bit, digital to analog outputs
- Double-buffered allowing simultaneous update of all DACs
- Analog output ranges of 0-2.5V, 0-5V, 0-10V, $\pm 2.5V$, $\pm 5V$, $\pm 10V$
- Single-ended and differential outputs on separate connectors
- PC/104 module size and mounting compatibility
- Rugged small-sized (4" x 4" x 1.25") steel enclosure
- Type B USB connector features industrial strength and high-retention design

FACTORY OPTIONS

- Resistors in series with differential connector for impedance matching
- DIN rail mounting provision
- Economy 'E' version available without screw terminal board
- OEM (board only) version with PC/104 mounting holes and PCB footprint for added flexibility in embedded applications

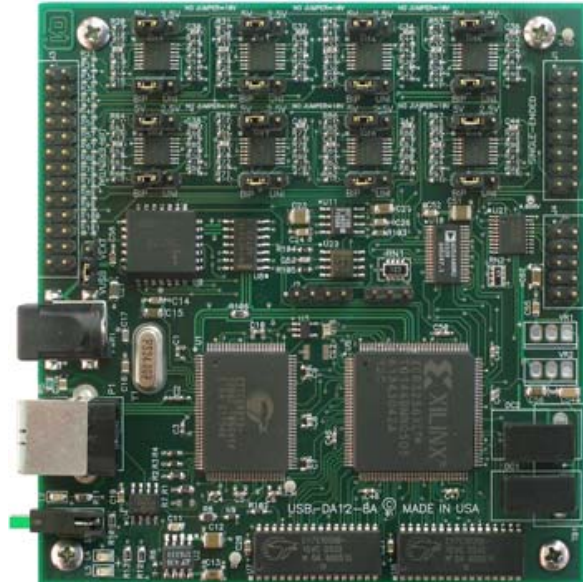

FUNCTIONAL DESCRIPTION

The USB-DA12-8A is an ideal solution for adding portable, easy-to-install analog outputs to any computer with a USB port. The USB-DA12-8A is a USB 2.0 device, offering the highest speed available with the USB bus. It is fully compatible with both USB 1.1 and USB 2.0 ports. The board is plug-and-play allowing quick connection whenever you need additional I/O on a USB port.

The USB-DA12-8A features 8 digital-to-analog converters (DACs) with both differential and single-ended outputs on separate connectors. The board features a variety of unipolar and bipolar ranges for each DAC giving the user a variety of options. The DACs can be updated individually or simultaneously. To ensure that there will not be excessive outputs to external circuits when the board is plugged in, automatic circuits limit analog outputs to zero volts. Power is supplied to the board via an external power supply which powers on board DC/DC converters which provide $\pm 12V$ to the operational amplifiers on the board. The I/O wiring connections for USB-DA12-8A are via an industry standard, IDC type 26-pin, 16-pin, and 10-pin connectors.

The USB-DA12-8A is designed to be used in rugged industrial environments but is small enough to fit nicely onto any desk or testing station. The board is PC/104 sized (3.550 by 3.775 inches) and ships with or without a steel powder-coated enclosure with an anti-skid bottom.



OEM USB/104 FORM FACTOR

The OEM (board only) version is perfect for a variety of embedded applications. What makes the OEM option unique is that its PCB size and mounting holes match the PC/104 form factor (without the bus connections). This allows our rugged digital board to be added to any PCI-104 or PC/104 stack by connecting it to a simple USB port usually included on-board with embedded CPU form factors such as EBX, EPIC, and PC/104. This is especially important since many newer CPU chipsets do not support ISA and have plenty of USB ports. The USB-DA12-8A OEM board can also be installed using standoffs inside other enclosures or systems.

High Retention USB Connector

The ever-growing presence of USB in the industrial/military marketplace has driven the need for USB connections to be reliable, dependable, and unailing. Gone are the days of loose USB connections. A type B USB connector is used on all USB/104 products which features a high retention design that complies with the class 1, Div II minimum withdrawal requirement of over 3 pounds of force (15 Newtons). This connector has an orange color-coded insulator to quickly differentiate it from standard USB connectors. Using these USB connectors increases reliability in your system and ensures a tight connection. For embedded OEM type applications, an additional miniature USB input header is provided in parallel with the type B connector.



Applications

- Portable
- Laptop
- Education
- Laboratory
- Industrial Automation
- Embedded OEM

SOFTWARE

The USB-DA12-8A is plug-and-play which allows quick connect or disconnect whenever you need additional I/O on your USB port. The module utilizes a high-speed custom function driver optimized for a maximum data throughput that is 50-100 times faster than the USB human interface device (HID) driver used by many competing products. This approach maximizes the full functionality of the hardware along with capitalizing the advantage of high-speed USB 2.0. The USB-DA12-8A is supported for use in most USB supported operating systems and includes a free Windows 98se/Me/2000/XP/2003 compatible software package. This package contains sample programs and source code in Visual Basic, Delphi, C++ Builder, and Visual C++ for Windows. Also incorporated is a graphical setup program in Windows. Third party support includes a Windows standard DLL interface usable from the most popular application programs. Embedded OS support include Windows XPe.

ACCESSORIES

The USB-DA12-8A is available with optional cable assemblies and screw termination boards.



Block Diagram

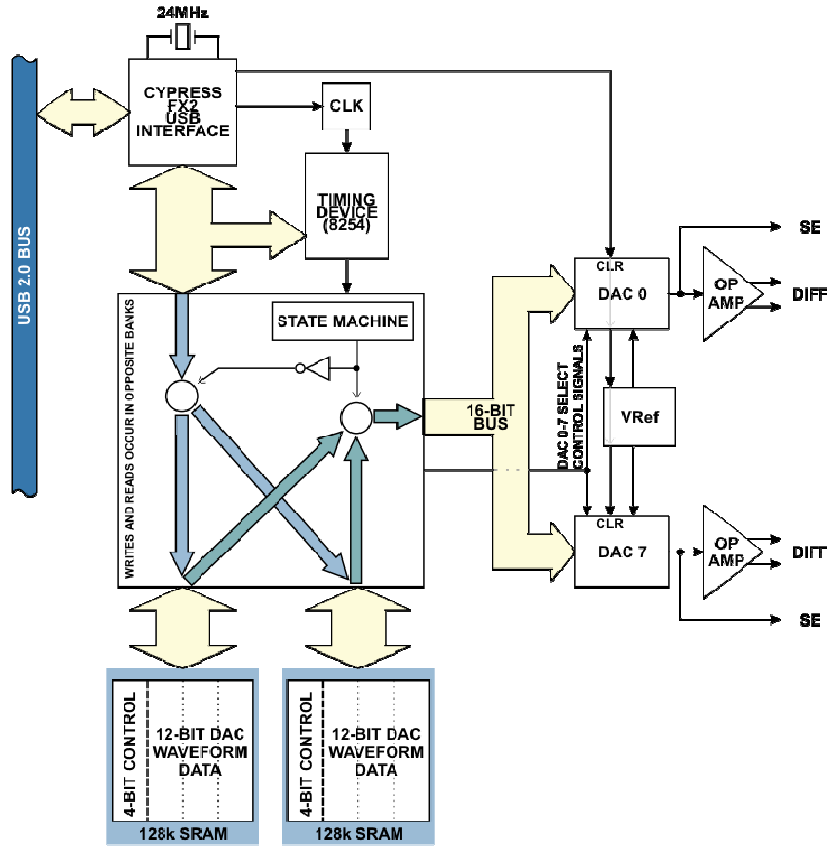

Specifications

Analog Outputs

- Number of Outputs: 8 channels
- Type of Outputs: Single-ended or differential
- Resolution: 12-bit resolution
- Unipolar Ranges: 0-2.5V, 0-5V, 0-10V
- Bipolar Ranges: $\pm 2.5V$, $\pm 5V$, $\pm 10V$
- Conversion Rate: buffered / non-streaming: 125K Samples per second x 8 channels. streaming: 400K samples per second TOTAL (ex: 25k Samples per second for 8 channels) Relative Accuracy: ± 2 LSB typical Differential Non-linearity: ± 0.2 LSB typical
- Settling Time: 8us typical, 10us max.

Environmental

- Operating Temperature Range: 0° to $70^{\circ}C$.
- Storage Temperature Range: -40° to $+85^{\circ}C$.
- Humidity: 5% to 95% non-condensing
- Board Dimension: 3.550 x 3.775 inches
- Box Dimension: 4 x 4 x 1.25 inches

Power

- Power supplied by +5VDC regulated AC/DC power supply
- +5VDC @ 520mA, typical (no load)
- $\pm 12VDC$ supplied from +5VDC through DC/DC Converters

Ordering Information

Item Codes	Description
USB-DA12-8A	Enclosure, module and screw terminal board
USB-DA12-8A-E	Economy model (no screw terminal board)
USB-DA12-8A-OEM	Board only (no enclosure or screw terminal board)
MP104-DIN	DIN rail mounting provision

Options

- P External power and AC/DC adapter