



MODEL USB-DIO-32

USER MANUAL

FILE: USB-DIO-32.A1d

Notice

The information in this document is provided for reference only. ADL Embedded Solutions Inc. does not assume any liability arising out of the application or use of the information or products described herein. This document may contain or reference information and products protected by copyrights or patents and does not convey any license under the patent rights of ADL Embedded Solutions Inc., nor the rights of others.

IBM PC, PC/XT, and PC/AT are registered trademarks of the International Business Machines Corporation.

Printed in USA. Copyright 2001, 2006 by ADL Embedded Solutions Inc., 4411 Morena Blvd. Suite 101, San Diego, CA 92117. All rights reserved.

WARNING!!

ALWAYS CONNECT AND DISCONNECT YOUR FIELD CABLING WITH THE COMPUTER POWER OFF. ALWAYS TURN COMPUTER POWER OFF BEFORE INSTALLING A CARD. CONNECTING AND DISCONNECTING CABLES, OR INSTALLING CARDS INTO A SYSTEM WITH THE COMPUTER OR FIELD POWER ON MAY CAUSE DAMAGE TO THE I/O CARD AND WILL VOID ALL WARRANTIES, IMPLIED OR EXPRESSED.

Table of Contents

Chapter 1: Introduction	4
Specifications	6
Figure 1-1: Block Diagram	8
Chapter 2: Installation	9
Chapter 3: Hardware Details	10
Figure 3-1: Option Selection Map	10
Chapter 4: USB Address Information	12
Chapter 5: Programming	13
Chapter 6: 8254 Counter/Timer	14
Chapter 7: Connector Pin Assignments	16
Table 7-1: 50-Pin Connector Pin Assignments	16

Chapter 1: Introduction

Features

- 32 lines of digital I/O
- High-speed USB 2.0 device, USB 1.1 backwards compatible
- Four 8-bit ports independently selectable for inputs or outputs
- All 32 I/O lines buffered with 32 mA source, 64mA sink current capabilities
- Three 82C54 counters capable of event counting, frequency measurement, pulse width measurement, or frequency generation
- Terminal block adapter card for easy wiring
- I/O Buffers can be enabled or tri-stated under program control
- Jumper selectable I/O pulled up to 5V for contact monitoring or pulled down to ground
- Jumper selectable power provided via USB cable or external power supply for higher current capabilities
- Resettable fused +5VDC output
- Standard 50pin IDC type connector with key
- PC/104 size (3.550 by 3.775 in.)
- Rugged industrial enclosure
- Compatible with Industry-Standard I/O Racks such as Gordos, OPTO22, Potter & Brumfield, etc. with optional cable

Applications

- Automatic Test Systems
- Laboratory Automation
- Robotics
- Machine Control
- Security Systems, Energy Management
- Relay Monitoring and Control
- Parallel Data Transfer to PC
- Sensing Switch Closures or TTL, DTL, CMOS Logic
- Driving Indicator Lights or Recorders

FUNCTIONAL DESCRIPTION

This USB board is an ideal solution for adding portable, easy-to-install digital I/O and counter capabilities to any computer with a USB port. The board is a USB 2.0 high speed device, offering the fastest speed available with the USB bus. It is fully compatible with both USB 1.1 and USB 2.0 ports. The card is plug-and-play allowing quick connect/disconnect whenever you need additional I/O on your USB port.

The board features 32 bits of TTL-compatible digital I/O with high-current capabilities and three 82C54 counters. Each digital port can be programmed to accept inputs or to drive outputs on four 8-bit ports, designated as port A, B, C, and D. Power is supplied to the card via the USB cable or for higher current capabilities, external power may be used. The I/O wiring connections are via an industry standard 50-pin connector or via a terminal block adapter card. For external circuits, fused +5VDC power is available at the connector. The resettable fuse is rated at 0.5A.

All I/O lines are buffered by a type 74ABT245 tristate buffer transceiver capable of sourcing 32 mA or sinking 64 mA. The buffers are configured under program control for input or output. Jumper selectable pull-ups (to +5 VDC) or pull-downs (to ground) on the card allow for contact monitoring and assure that there are no erroneous outputs at power-up until the card is initialized by system software. This jumper can be removed to provide a floating state for the I/O when it is neither pulled up nor down.

Unlike most USB digital I/O products which primarily use a human interface device (HID) driver, we provide an easy to use, Windows-based, custom function driver optimized for maximum data throughput. This approach exposes the full functionality of the hardware along with maximizing the advantage of using the high-speed USB 2.0 bus.

The board is designed to be used in rugged industrial environments but is small enough to fit nicely onto any desk or testing station. The board is PC/104 size (3.550 by 3.775 inches) and ships inside a steel powder-coated enclosure with an anti-skid bottom.

COUNTER/TIMERS

Available on the board are three 82C54 counters that each include three 16-bit counter/timers factory configured in an optimal module for use as event counters, frequency output, pulse width, and frequency measurement (see the Block Diagram at the end of this chapter).

Specifications

Digital Inputs (TTL Compatible)

- Logic High: 2.0 VDC min, 5.5 VDC max
- Logic Low: 0.8 VDC max, -0.5 VDC min

Digital Outputs

- Logic High: 2.0 VDC min., source 32 mA
- Logic Low: 0.55 VDC max., sink 64 mA

Counter/Timers

- Type: 82C54-10 programmable interval counters
- Output Drive: 2.0 VDC min., source 32 mA
0.55 VDC max., sink 64 mA
- Maximum Input Frequency: 10MHz
- Input Gate: TTL/CMOS compatible
- Clock: On-board, 3 MHz crystal-controlled clock
- Active Count Edge: Negative edge
- Minimum Clock Pulse Width: 30 ns high, 40 ns low
- Timer Range: 16 bits

Bus Type

- USB2.0 high-speed (480 Mb/s)

Power

- Basic unit: 80 mA typical (no load)
- +5 VDC from the USB bus or external power supply depending on user configuration. The USB bus is specified to provide 500 mA to most desktop environments. This gives you 420 mA available (500mA - 80mA = 420mA). If using more than a total of 500mA, use optional 9 VDC (on board voltage regulator outputs +5 VDC to card) external power supply and **remove** VUSB jumper and place jumper on VEXT. Then plug in external power before plugging into USB port . This option will give you a total of 1000mA available.
- +5V resettable fuse at 0.5A located on connector.

Environmental

- Operating Temperature Range: 0 °C. to 70 °C.
- Storage Temperature Range: -40 °C. to +85 °C.
- Humidity: 0 to 90% RH, non-condensing.
- Board Dimension: 3.550 x 3.775 inches.
- Box Dimension: 4.00 x 4.00" x 1.25 inches.

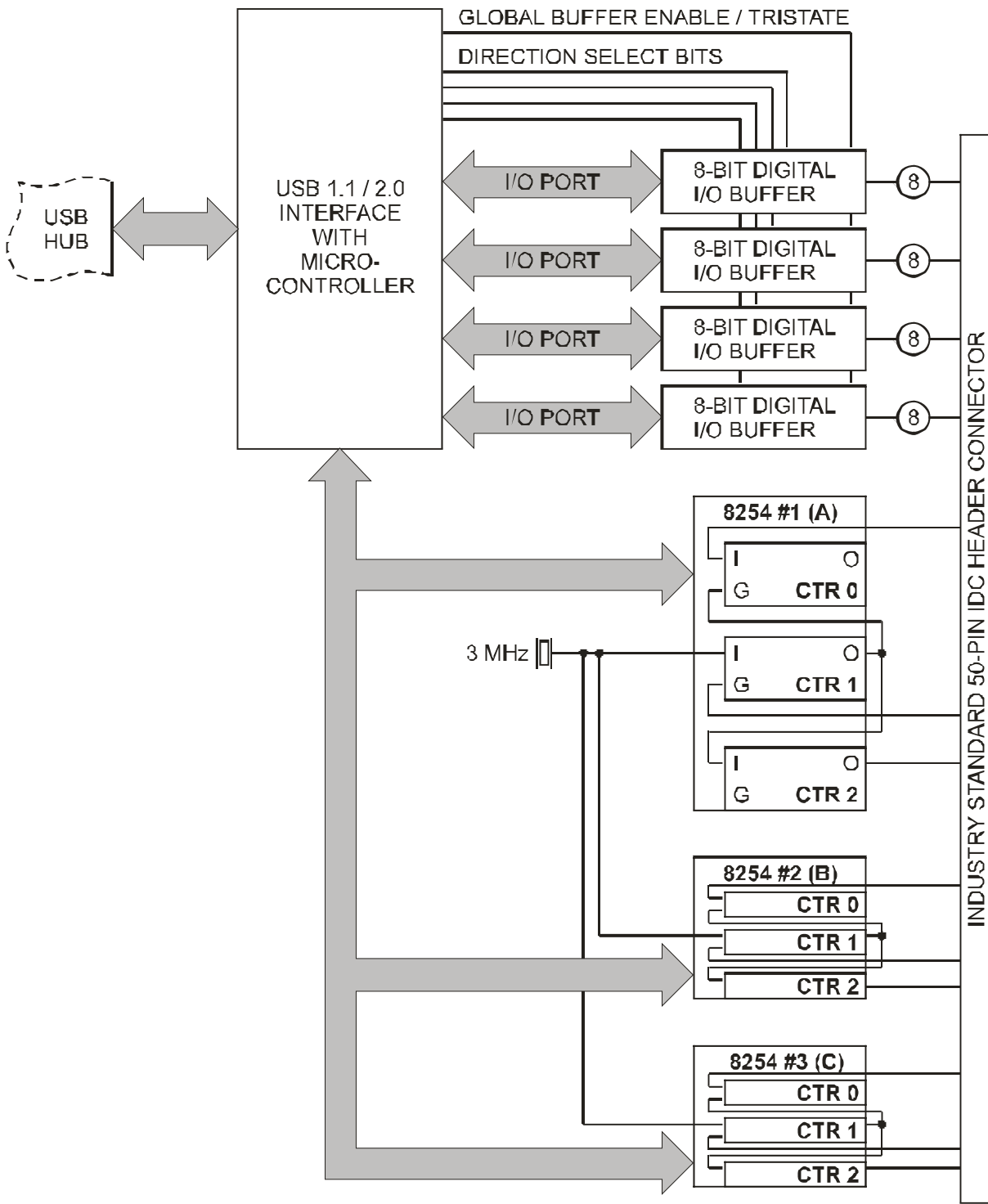

Figure 1-1: Block Diagram

Chapter 2: Installation

Software CD Installation

These paragraphs are intended to detail the software installation steps as well as describe what is being installed.

The software provided with this board is contained on one CD and must be installed onto your hard disk prior to use. To do this, perform the following steps as appropriate for your software format and operating system. Substitute the appropriate drive letter for your CD-ROM or disk drive where you see X. in the examples below.

WIN95/98/Me/NT/2000/XP/2003

- a. Place the CD into your CD-ROM drive.
- b. The CD should automatically run the install program. If the install program does not click START | RUN and type X.] b g h U ` ` , click OK or press ? .
- c. Follow the on-screen prompts to install the software for this board.

Hardware Installation

The board can be installed in any USB 2.0 or USB 1.1 port. Please refer to the USB I/O Quick Start Guide which can be found on the CD, for specific, quick steps to complete the hardware and software installation.

Chapter 3: Hardware Details

Option Selections

Refer to the setup programs on the CD provided with the board. Also, refer to the Block Diagram and the Option Selection Map when reading this section of the manual.

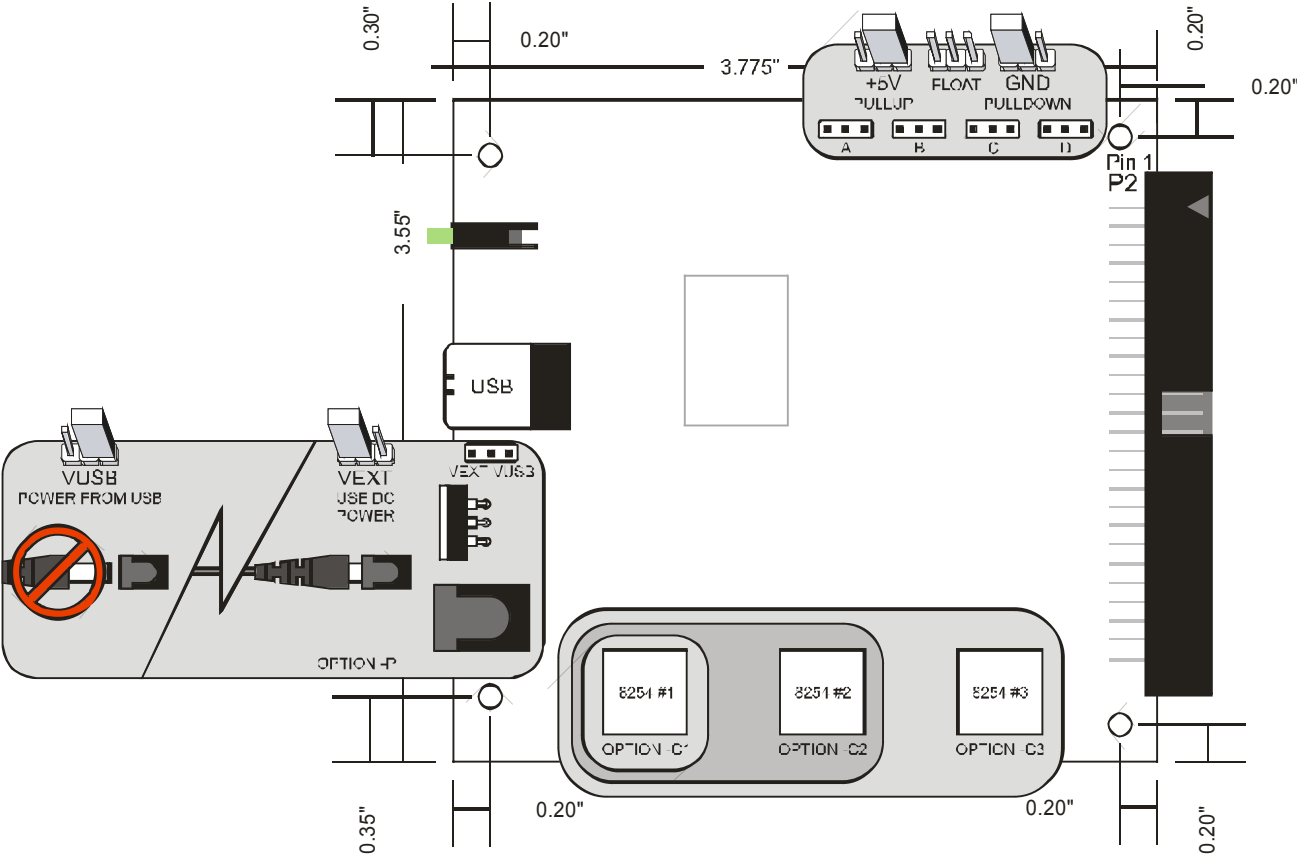

Figure 3-1: Option Selection Map

USB CONNECTOR

The USB connector is a Type B connector and mates with the cable provided. The USB port provides communication signals along with +5 VDC power. The board can be powered from the USB port or, if needed for higher current applications, an external power supply can be used.

LED

The LED on the front of the enclosure is used to indicate power and data transmissions. When the LED is in an illuminated steady green state, this signifies that the board is successfully connected to the computer and has been detected and configured by the operating system. When the LED flashes continuously, this signifies that there is data being transmitted over the USB bus.

DC POWER JACK (OPTIONAL)

This is an option for high current applications when more current is needed than what your computer can provide on the USB port (typically 500 mA). The DC jack has a 2.00mm post on board and is designed to be used with the 9 VDC AC/DC external power supply that ships with this option. The voltage regulator on board regulates the 9 VDC and provides 5 VDC to the onboard circuitry. When using external power, switch the jumper located near the USB connector to VEXT, otherwise when the jumper is in the VUSB position current is drawn from the USB port (please consult the option selection map for a visual reference).

50 PIN BOX HEADER

The 50 pin box header has standard .100" spacing between pins and is keyed to prevent improper connections. It can be used with standard IDC type ribbon cables or the screw terminal board that plugs directly into the box header.

Chapter 4: USB Address Information

Use the provided driver to access the USB board. This driver will allow you to determine how many supported USB devices are currently installed, and each device's type. This information is returned as a Vendor ID (VID), Product ID (PID) and Device Index.

The board's VID is "0x1605", and its PID is "0x8001".

The Device Index is determined by how many of the device you have in your system, and provides a unique identifier allowing you to access a specific board at will.

Chapter 5: Programming

The driver software provided with the board uses a 32-bit .dll front end compatible with any Windows programming language. Samples provided in Borland C++Builder, Borland Delphi, Microsoft Visual Basic, and Microsoft Visual C++ demonstrate the use of the driver.

The following functions are provided by the driver in Windows.

These functions will allow you to read or write individual bits, bytes, or the entire board worth of data. In addition, counter-timer functionality and board-level functions complete the driver package.

For detailed information on each function refer to the .html Driver Manual located in the Win32 directory for this board.

```
unsigned long GetDevices(void )
unsigned long QueryDeviceInfo(DeviceIndex, pPID, pName, pDIOBytes, pCounters)
unsigned long DIO_Configure(DeviceIndex, bTristate, pOutMask, pData)
unsigned long DIO_Write1(DeviceIndex, BitIndex, bData)
unsigned long DIO_Write8(DeviceIndex, ByteIndex, Data)
unsigned long DIO_WriteAll(DeviceIndex,pData)
unsigned long DIO_Read8(DeviceIndex, ByteIndex,pBuffer)
unsigned long DIO_ReadAll(DeviceIndex,Buffer)
unsigned long CTR_8254Mode(DeviceIndex, BlockIndex, CounterIndex, Mode)
unsigned long CTR_8254ModeLoad(DeviceIndex, BlockIndex, CounterIndex,Mode, LoadValue)
unsigned long CTR_8254ReadModeLoad(DeviceIndex, BlockIndex, CounterIndex, Mode, LoadValue ,
pReadValue)
unsigned long CTR_8254Read(DeviceIndex, BlockIndex, CounterIndex, pReadValue)
unsigned long CTR_StartOutputFreq(DeviceIndex, CounterIndex, pHz)
```

Chapter 6: 8254 Counter/Timer

These boards have the option of one, two, or three 82C54 counter(s) that each include three 16-bit counter/timers factory configured in an optimal module for use as event counters, frequency output, pulse width, and frequency measurement (See Block Diagram). Each counter can be programmed to any count as low as 1 or 2, and up to 65,536, depending on the mode chosen. For those interested in more detailed information, a full description can be found in the Intel (or equivalent manufacturer's) data sheet, provided in the /chipdocs directory on the Software Master CD.

Refer to Chapter 5: Programming, and the .html Driver Manual document installed by the Software Master CD for information on using the installed software driver for this board. The following data is provided only for reference, as it is unlikely to be needed when using the provided driver. Please note the block diagram description of how the 9 pins associated with 8254 counters are configured into an optimum counter-timer module on this board.

Operational Modes

The 8254 modes of operation are described in the following paragraphs to familiarize you with the versatility and power of this device. For those interested in more detailed information, a full description of the 8254 programmable interval timer can be found in the Intel (or equivalent manufacturers') data sheets. The following conventions apply for use in describing operation of the 8254 :

Clock:	A positive pulse into the counter's clock input
Trigger:	A rising edge input to the counter's gate input
Counter Loading:	Programming a binary count into the counter

Mode 0: Pulse on Terminal Count

After the counter is loaded, the output is set low and will remain low until the counter decrements to zero. The output then goes high and remains high until a new count is loaded into the counter. A trigger enables the counter to start decrementing.

Mode 1: Retriggerable One-Shot

The output goes low on the clock pulse following a trigger to begin the one-shot pulse and goes high when the counter reaches zero. Additional triggers result in reloading the count and starting the cycle over. If a trigger occurs before the counter decrements to zero, a new count is loaded. This forms a retriggerable one-shot. In mode 1, a low output pulse is provided with a period equal to the counter count-down time.

Mode 2: Rate Generator

This mode provides a divide-by-N capability where N is the count loaded into the counter. When triggered, the counter output goes low for one clock period after N counts, reloads the initial count, and the cycle starts over. This mode is periodic, the same sequence is repeated indefinitely until the gate input is brought low. This mode also works well as an alternative to mode 0 for event counting.

Mode 3: Square Wave Generator

This mode operates like mode 2. The output is high for half of the count and low for the other half. If the count is even, then the output is a symmetrical square wave. If the count is odd, then the output is high for $(N+1)/2$ counts and low for $(N-1)/2$ counts. Periodic triggering or frequency synthesis are two possible applications for this mode. Note that in this mode, to achieve the square wave, the counter

decrements by two for the total loaded count, then reloads and decrements by two for the second part of the wave form.

Mode 4: Software Triggered Strobe

This mode sets the output high and, when the count is loaded, the counter begins to count down. When the counter reaches zero, the output will go low for one input period. The counter must be reloaded to repeat the cycle. A low gate input will inhibit the counter.

Mode 5: Hardware Triggered Strobe

In this mode, the counter will start counting after the rising edge of the trigger input and will go low for one clock period when the terminal count is reached. The counter is retriggerable. The output will not go low until the full count after the rising edge of the trigger.

Chapter 7: Connector Pin Assignments

A 50-pin connector provided on the back plate of these boards for I/O connections. Connector pin assignments are listed below.

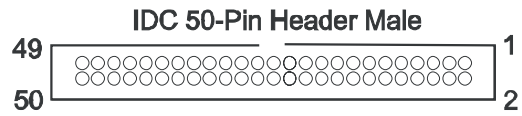

Table 7-1: 50-Pin Connector Pin Assignments

Pin	Function	Pin	Function
1	C7	2	COUNTER A0 IN
3	C6	4	GATE A1
5	C5	6	OUT A2
7	C4	8	COUNTER B0 IN
9	C3	10	GATE B1
11	C2	12	OUT B2
13	C1	14	COUNTER C0 IN
15	C0	16	GATE C1
17	B7	18	OUT C2
19	B6	20	D7
21	B5	22	D6
23	B4	24	GROUND
25	B3	26	D5
27	B2	28	GROUND
29	B1	30	D4
31	B0	32	GROUND
33	A7	34	D3
35	A6	36	D2
37	A5	38	D2
39	A4	40	GROUND
41	A3	42	D1
43	A2	44	GROUND
45	A1	46	D0
47	A0	48	GROUND
49	+5V VDC	50	GROUND

Customer Comments

If you experience any problems with this manual or just want to give us some feedback, please email us at: sales@adl-usa.com. Please detail any errors you find and include your mailing address so that we can send you any manual updates.



ADL Embedded Solutions Inc., 4411 Morena Blvd., Suite 101, San Diego, CA 92117-4345
P. +1 858 490-0597 F. +1 858 490-0599
e-mail: sales@adl-usa.com; web: www.adl-usa.com